



Item # _____

RCB / RSCB Char-Rock Broilers



STANDARD FEATURES:

- ◆ Compact heavy gauge chassis for long life.
- ◆ Stainless steel sides and front valve cover.
- ◆ Double wall panels for better insulation.
- ◆ All welded fire box liner supports char-rock grates.
- ◆ "H"-Type cast iron burner, rated at 35,000 BTU/hr., for the snack line and 40,000 BTU / hr. for the heavy duty line.
- ◆ Manual control to individually operate each burner.
- ◆ Heavy cast iron top and bottom grates.
- ◆ Full width removable crumb pan.

RCB-24
Shown

OPTIONS:

- ◆ Stainless Steel Stand
- ◆ Casters for stand

Royal Char-Rock Broilers have user friendly heavy duty features with easy to clean stainless steel front and side panels. Standard top grates may lay flat or be set on an angle to channel grease and minimize flare up. The char-rock style broiler allows for a moist heat and creates unique flavor. Both heavy duty and snack series units come equipped with cast iron burners for even heat distribution. Heavy cast iron bottom grates support the lava rock bed inside a 14 gauge welded fire box liner. Burners, grates, as well as the fire box, are removable for maintenance without special tools.

ROYAL RANGE OF CALIFORNIA, INC.
3245 CORRIDOR DRIVE, EASTVALE, CA 91752
(800) 769-2414 in the U.S. (951) 360-1600 Fax: (951) 360-7500
www.royalranges.com E-mail: royalrange@dslextreme.com

PRINTED IN THE U.S.A. (08/11)



Char-rock Broiler Specifications

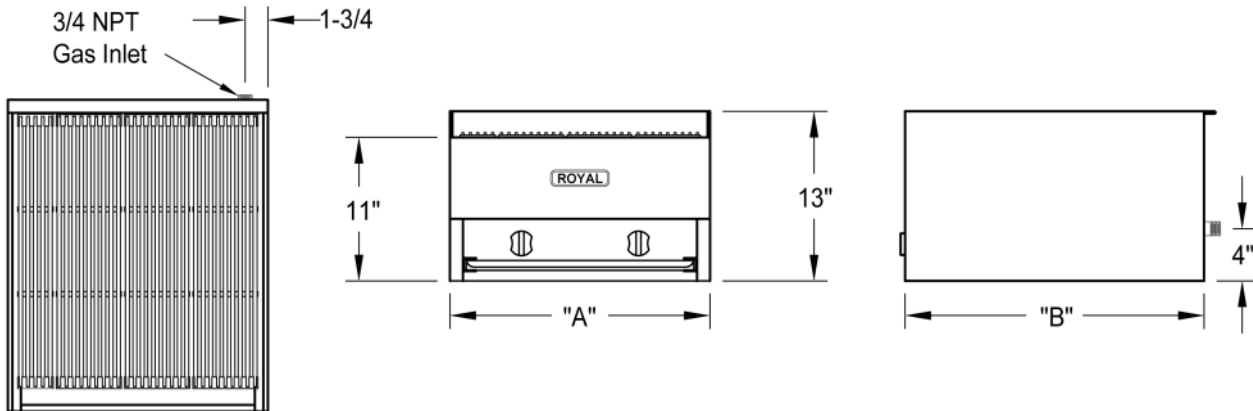

Snack (RSCB Models)

MODEL NO.	WIDTH (A)	DEPTH (B)	NUMBER OF BURNERS *	TOTAL BTU	SHIP WEIGHT
RSCB-12	12"	23"	1	35,000	113 Lbs.
RSCB-18	18"	23"	1	35,000	135 Lbs.
RSCB-24	24"	23"	2	70,000	160 Lbs.
RSCB-36	36"	23"	3	105,000	268 Lbs.
RSCB-48	48"	23"	4	140,000	395 Lbs.

* Snack size (cast iron "H") burners @ 35,000 BTU/hr. each.

Heavy Duty (RCB Models)

MODEL NO.	WIDTH (A)	DEPTH (B)	NUMBER OF BURNERS *	TOTAL BTU	SHIP WEIGHT
RCB-18	18"	28"	1	40,000	240 Lbs.
RCB-24	24"	28"	2	80,000	262 Lbs.
RCB-30	30"	28"	3	120,000	309 Lbs.
RCB-36	36"	28"	3	120,000	383 Lbs.
RCB-48	48"	28"	4	160,000	441 Lbs.
RCB-60	60"	28"	5	200,000	498 Lbs.

* Heavy duty size (cast iron "H") burners @ 40,000 BTU/hr. each

Gas Connection: 3/4" NPT on the right hand rear of the appliance
The pressure regulator (supplied) is to be connected here by the installer.

Gas pressure: 5" W.C. - Natural Gas
10" W.C. - Propane

Combustible Clearances:

For use only in
non-combustible locations

Non-combustible Clearances:

0 inches sides
0 inches rear

**Specify type of gas and altitude,
if over 2,000 feet, when ordering.**

Due to continuing product development to ensure best possible performance, these specifications are subject to change without prior notification