

Item # \_\_\_\_\_



# ***RMG / RSMG*** **Manual Griddles, Combinations**



**RSMG-36 Shown**

### **STANDARD FEATURES:**

- ◆ Compact heavy gauge chassis for long life.
- ◆ Stainless steel sides and front valve cover.
- ◆ Double side panels for better insulation.
- ◆ Cast iron lift off head burners rated at 30,000 BTU / hr in the hot plate section.
- ◆ Heavy duty burner every 12", rated at 20,000 BTU/hr for the snack line and 30,000 BTU/hr for the heavy duty line.
- ◆ Manual control for each burner.
- ◆ 3/4" thick griddle plate with polished cooking surface on heavy duty models
- ◆ 5/8" thick griddle plate with polished cooking surface on the snack series.
- ◆ 4" wide grease trough with large drain opening for easy cleaning.
- ◆ Full width removable crumb pan under open burners.
- ◆ Large 1-1/2 gallon capacity grease can.
- ◆ 4" high adjustable heavy duty legs included.

### **OPTIONS:**

- ◆ 1" thick griddle plate.
- ◆ 10" diameter Stainless Steel wok rings to fit on top grate.
- ◆ Interchangeable wok or saute burner heads.
- ◆ Thermostat control for the griddle, see RTG/RSTG series.
- ◆ Stainless steel stand with adjustable legs.
- ◆ Casters for stand.

*Royal manual griddles and hot plate / griddle combinations are designed for optimum performance, durability, easy cleanup and maintenance. The griddles feature 30,000 BTU "U" burners in the heavy duty and combo units with 20,000 BTU / hr on the snack line. The open burner sections all feature our unique two piece lift off burner head rated at 30,000 BTU/hr. Each burner has an individual heavy duty brass control and a standing pilot for easy safe ignition. The griddle plates are highly polished with a spatula width grease trough. Open burners are covered by a 12" x 12" heavy cast iron grate. You can select two or four open top burners per unit to add flexibility to the space constrained cooking lineup. A heavy all stainless steel plate ledge complements either section and aids in food preparation and serving.*



## Griddle and Combination Specifications

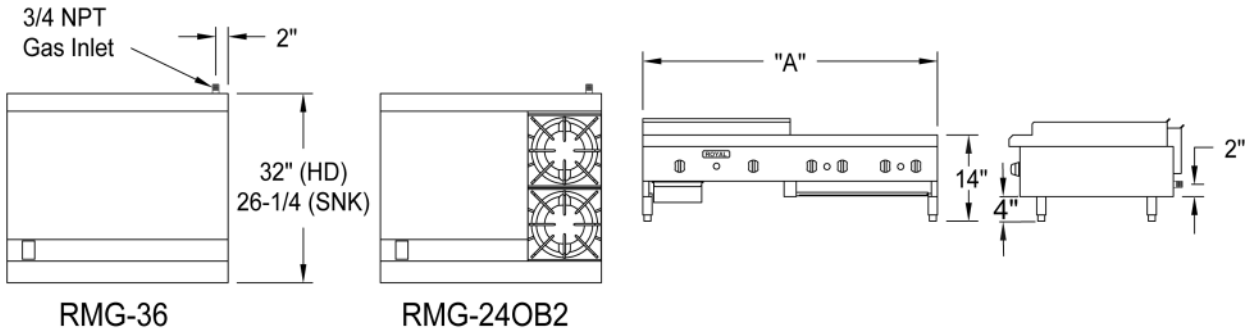

<b>Snack Griddle (RSMG Models)</b>					
MODEL NO.	WIDTH (A)	DEPTH	NUMBER OF BURNERS *	TOTAL BTU	SHIP WEIGHT
RSMG-12	12"	26-1/4"	1	20,000	120 Lbs.
RSMG-18	18"	26-1/4"	1	20,000	142 Lbs.
RSMG-24	24"	26-1/4"	2	40,000	175 Lbs.
RSMG-36	36"	26-1/4"	3	60,000	240 Lbs.
RSMG-48	48"	26-1/4"	4	80,000	305 Lbs.
RSMG-60	60"	26-1/4"	5	100,000	380 Lbs.
* Snack griddle burners @ 20,000 BTU/hr each					
<b>Heavy Duty Griddle (RMG Models)</b>					
MODEL NO.	WIDTH (A)	DEPTH	NUMBER OF BURNERS *	TOTAL BTU	SHIP WEIGHT
RMG-12	12"	32"	1	30,000	140 Lbs.
RMG-18	18"	32"	1	30,000	165 Lbs.
RMG-24	24"	32"	2	60,000	210 Lbs.
RMG-36	36"	32"	3	90,000	290 Lbs.
RMG-48	48"	32"	4	120,000	370 Lbs.
RMG-60	60"	32"	5	150,000	460 Lbs.
RMG-72	72"	32"	6	180,000	540 Lbs.
* Heavy duty griddle burners @ 30,000 BTU/hr each					
<b>Griddle Hotplate Combination</b>					
MODEL NO.	WIDTH (A)	DEPTH	NUMBER OF BURNERS *	TOTAL BTU	SHIP WEIGHT
RMG-12OB2	24"	32"	1 G / 2 OB	90,000	295 Lbs.
RMG-24OB2	36"	32"	2 G / 2 OB	120,000	405 Lbs.
RMG-24OB4	48"	32"	2 G / 4 OB	180,000	465 Lbs.
RMG-36OB2	48"	32"	3 G / 2 OB	150,000	535 Lbs.
RMG-36OB4	60"	32"	3 G / 4 OB	210,000	595 Lbs.
RMG-48OB2	60"	32"	4 G / 2 OB	180,000	695 Lbs.
RMG-48OB4	72"	32"	4 G / 4 OB	240,000	864 Lbs.
* G = heavy duty griddle burners @ 30,000 BTU/hr each OB = open burners @ 30,000 BTU/hr each					

**Gas Connection:** 3/4" NPT on the right hand rear of the appliance  
 The pressure regulator (supplied) is to be connected here by the installer.

**Gas pressure:** 5" W.C. - Natural Gas  
 10" W.C. - Propane

**Combustible Clearances:**

15 inches sides  
 6 inches rear

**Non-combustible Clearances:**

0 inches sides  
 0 inches rear

**Specify type of gas and altitude,**  
 if over 2,000 feet, when ordering.

*Due to continuing product development to ensure best possible performance, these specifications are subject to change without prior notification*